



Film capacitor – Power Factor Correction

Power factor controller

Series/Type: B44066R****A***
Ordering code: B44066R5615A415
Date: 2023-09-19
Version: 1

Preliminary data
Applications

- Power factor correction

Features

- Intelligent and high-speed capacitor switching control
- Self-optimizing control capability by ARM micro-processor
- Wide range of auxiliary power supply with AC or DC input
- Large measuring voltage range
- Four-quadrant operation (e.g. stand by generator / solar co- gen)
- High precision of measurement
- Phase sequence of measurement voltage
- Easy edit mode (to program minimum parameters)
- Expert edit mode facility to access special functions
- Minimum current sensing 5mA
- Storage of maximum values, maximum demand, Energy values
- Storage of switching operations and time + Capacitor utilization
- Monitoring of capacitor kVA_r
- One auxiliary input and three auxiliary outputs
- Measurement methods like 3 wattmeter / 2 wattmeter / balanced quadrature / balanced in-phase
- External temperature monitoring facility via PT100 sensor (RTD)
- Capacitor Current monitoring protection for Neutral / Earth current monitoring and harmonics
- Measurement Odd & Even harmonics up to 31st for Supply Voltage (LL, LN), Current, Capacitor current
- IOT enable with GPRS real time data (thro' external modem) / MODBUS connectivity
- Internal Data logging, history of fault detection, load pattern, time storage parameters
- Mono-phase and balanced capacitor through controlling single phase & three phase capacitor duty contactors
- RoHS-compatible
- CE marking

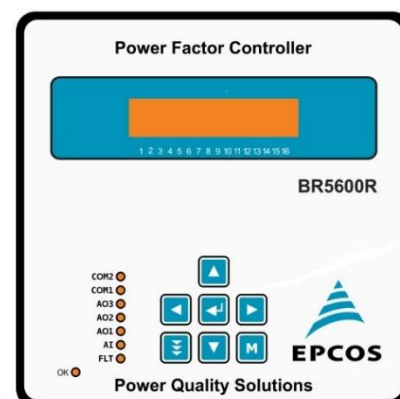
Inputs

- Power Supply Voltage: 90V to 485V L-L / 100V to 550Vdc with OV cutoff. (absolute maximum rating 550V L-L)
- Measurement voltage 50....315V ~(L-N) / 85..... 550V ~(L-L)
- Current X:1A / X:5A (for supply current and capacitor current)
- Standard service interface (for e.g. firmware update)
- Additional external input (110.... 230V)

Preliminary data

Outputs

- 15 relay outputs for capacitor control. 0.5Amp/ 250V ~inductive load NO-type
- 3 auxiliary outputs configurable for alarm and control functions

Measuring and display of grid and capacitor parameters

- Voltage, current, frequency
- Active, reactive, apparent and distortion power
- Power factor (PF and DPF), uncompensated reactive power
- Energy import and export (active, reactive, apparent)
- Maximum demand (kVA, kW)
- Harmonics of voltage L-L & L-N (up to 31st linear)
- Harmonics of current (up to 31st linear)
- Harmonics of capacitor current (up to 31st linear)
- THD-V, THD-I, THD-C (in terms of % and values)
- Temperature (internal and external via PT100)
- Display storage of maximum values, switching operations and operating times
- 3 auxiliary outputs configurable for alarm and control functions
- Capacitor kVAr detection of normalized values (removing effect of change in voltage, frequency and harmonics)

Operation

- LCD display 16 characters x 2 lines
- User friendly 7 keys soft-touch keypad
- Simple self-explanatory menu navigation
- Plain language menu in English

Preliminary data

PFrms = 0.978 C DPF = 0.995 C	IND. 0.997 ↑ IOK +--+ D x X _ _	DPF 0.998 I 0.998 C 1.000 C
Amp-Av= 1.723 KA VoltLL= 433.8 V	Phase Sequence R-Y-B	VLN-RYB 224.5 V 222.8 V 225.2 V
P = 1131.4 KW P1 = 951.99 KW		VLL-RYB 389.7 V 387.2 V 390.0 V
Q = 239.11 KVAR Q1 = 197.84 KVAR		Amp-RYB 1.783KA 1.821KA 1.699KA
S = 1156.8 KVA S1 = 972.33 KVA		AmpC-RYB 635.5 A 638.2 A 629.9 A
D = 443.68 KVA Dx = 626.71 KVA		Amp-N 34.94 A AmpC-EL 0.049 A
VTHD-F = 2.523% ATHD-F = 21.78%		RP = 388.16 KW RP1 = 364.90 KW
AmpC-Av=1.060 KA Freq. = 50.1 Hz		RQ = 91.738 KVAR RQ1= 82.665 KVAR
UQ1= 733.98 KVAR CQ1= 536.14 KVAR		RS = 418.44 KVA RS1 = 404.69 KVA
UnbalanceV: 0.3% A:12.4% C: 2.2%		RDx = 101.25 KVA RD = 78.334 KVA
		RUQ1= 926.41 VAr RCQ1= 369.89KVAR

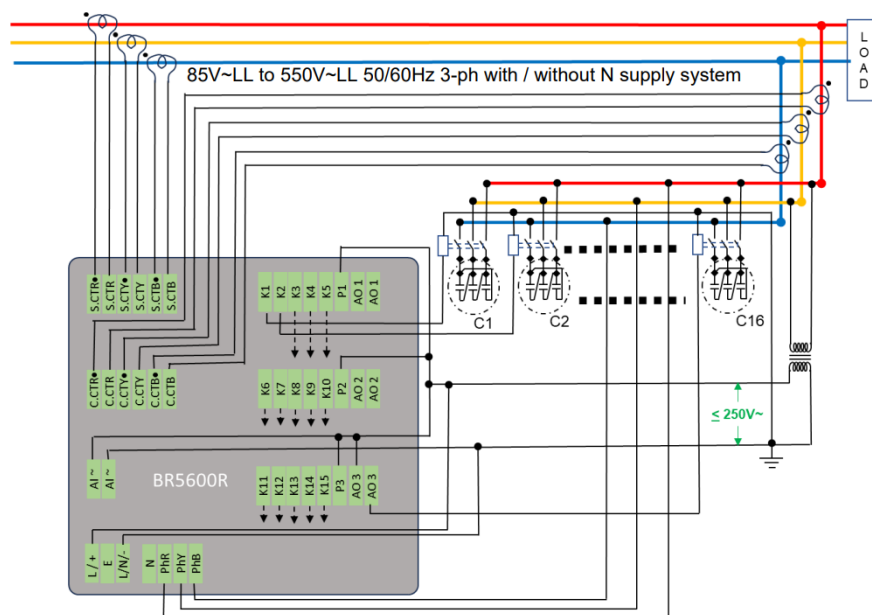
Connection
3-Wire Balanced Load connection to LV Auto-PF system:

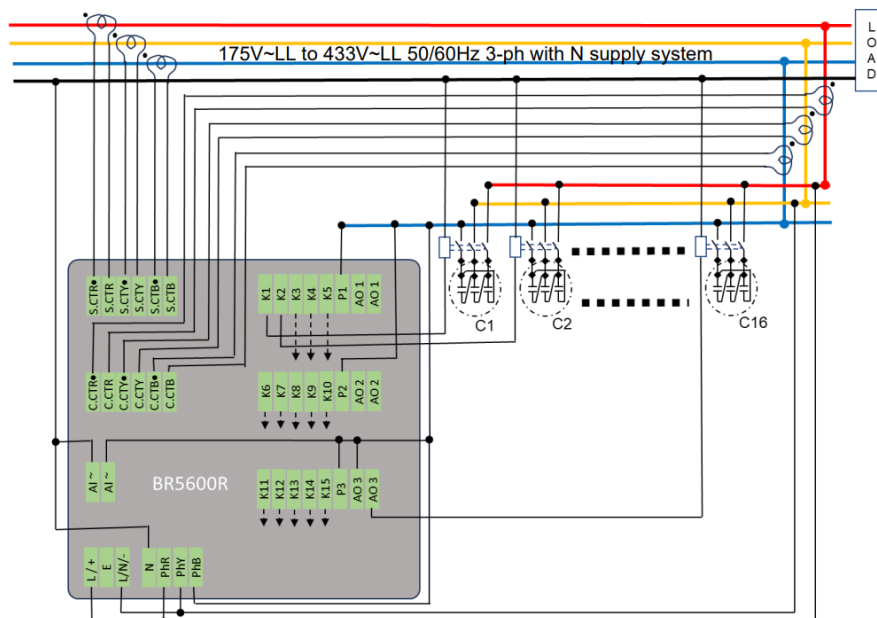
Preliminary data
4-Wire Balanced Load with Neutral connection to LV Auto-PF system:

Communication

- Interface RS232 communication –
 - COM1 (RS232) serial communication port used for PC-app (PF-Dataview)
 - AT+ command (3GPP) communication with GPRS modem (supporting https:// protocol)
- Interface RS485 (MODBUS RTU)
 - COM2 (RS485) serial MODBUS communication port
 - RM1 (remote command receiver) through MODBUS communication from remote measurement meter.
- **Data logging**
 - Various types of data stored in BR5600R non-volatile memory (E² PROM)
 - Three types of data storage
 - Faults/events log
 - Daily log (every 24hrs at day change)
 - Interval log (User set time slot) – 5/10/15/30/60/120 minutes and user set data size options as 64/128/256/512 bytes per saved record
 - User settings data storage (available to user through communication channels)
- **Internal clock (with super capacitor backup)**
 - Power down back-up time for clock is >30 days (10°to 40°C ambient)
 - Creation time / date stamps for events, interval and daily logs
 - Time /date stamp update from GPRS network connection

Preliminary data

Time based reset for maximum values, maximum demand, energy counters

■ Programmable auxiliary input

Monitor the control ac supply healthiness. This is given to auxiliary control functions

Enable /disable PF correction action

Switch over 2nd target cos-phi (Generator)

HOLD – the correction time is extended infinitely till the digit1 is observed in this port

(0V to 10V – No action; 68V to 290 – capacitor on hold)

Master – master holds position command received from other unit in follower operation

Follower - follower receives command for enabling the normal capacitor control operation

■ Three programmable auxiliary output

Fan ON/OFF for temperature control

ALARM annunciation indicative faults

ALARM capacitor trip annunciation, faults that trips all capacitors

ALARM for auto synchronous failure

Capacitor unbalance current (neutral/earth current in case of 3CT capacitor connection only)

Internal temperature exceeding alarm

Clock time failure

GPRS communication data pending

GPRS communication error

Unit healthy function indicator

Additional cap bank (only applicable for 3rd auxiliary output)

Technical data and specification

Operating voltage	90V to 485Vac L-L / 100V to 550Vdc
Measuring voltage	50....315Vac ~(L-N) / 85..... 550Vac ~(L-L)
Measuring current	X : 1A / X : 5A (for supply current and capacitor current)
Power consumption	< 5VA
Sensitivity	5mA
Switching output	
Relay output for capacitor branches	15 can be extended to 16 (through auxiliary output 3)
Auxiliary outputs	3 (programmable)

Preliminary data

Switching power	250VAC, 0.5A Inductive and 1000W resistive load
Number of active output	Programmable
Operation and display	
Display	LCD display 16 characters x 2 lines
Menu language	English
Freely editable control series	User programable
Control	
Control principle	Intelligent switching behavior, 4 quadrant operation
Automatic initialization /test run	Possible
Target PF	0.1 Inductive up to 0.1 capacitive
Correction time	Selectable from 1 sec to 3600 sec
Discharge time	Selectable from 1 sec to 7200 sec
Interleaving time delay	Selectable from 0.5 sec to 60 sec
Manual Operation	Yes
Fixed steps /skip steps	Programmable
Zero voltage release	Standard
Display/display function	
Display of grid parameters	PF, V, I, F, active, reactive, apparent power, THD-V, THD-I
PF display	Up to 3 rd decimal point
Display of harmonics	Up to 31 st harmonics (odd and even)
Accuracy	Current / voltage :1%, active, apparent and reactive power: 2%
Storage function	
Storage of maximum values	Voltage, current, active, reactive, apparent power, temperature, THD-V, THD-I
Storage of switching operations	Available (each output can be reset separately)
Storage of operation time	Available (each capacitor can be reset separately)
Events storage	latest 512 events/ faults for TCP-V01 protocol and 256 for https:// protocol are available in memory. User can be download and view through data downloading software

Temperature monitoring

Preliminary data

Monitoring	Automatic steps switch off
Temperature measuring range(internal)	0.....+65 °C
Temperature measuring range(external – via PT100)	0.....+100 °C
Casing	
Panel mounted instruments	146x146x75 mm, panel cut out dimension 139x139mm
Weight	1.25kg
Ambient operating temperature	0.....+60 °C
Protection class according to IEC 62059	Front : IP54, rear : IP20
Safety regulations	IEC 61010-1
Interference resistance	IEC 61326-1
EMC-interference	IEC 61326-1
Over voltage category	III
Pollution degree	2
Ordering code	B44066R5615A415

Preliminary data

Cautions and warnings

Controller hunting : When putting the capacitor bank in operation, it is required to avoid needless switching cycles (permanent switching on and off of steps without significant change of consumer load). This is called “controller hunting” would increase the number of switching operations of the connected contactors and capacitors and decrease the expected life cycle (wear out) and, in worst case, capacitor busting and fire etc. This can be avoided by a proper programming of BR5600R with the actual system parameters (current transformer primary and secondary, first step kvar, switching time)

Please read cautions information about PFC capacitors and cautions as well as installation and maintenance instructions in the actual version of the Product Profile Power Factor Correction to ensure optimum performance and prevent products from failing, and in worst case, bursting and fire, etc. The actual Product Profile is available at www.tdk-electronics.tdk.com. Information given in the PFC-product profile and values given in the data sheet reflect typical specifications. You are kindly requested to approve our product specifications or request our approval for your specification before ordering.

Important notes

The following applies to all products named in this publication:

1. Some parts of this publication contain **statements about the suitability of our products for certain areas of application**. These statements are based on our knowledge of typical requirements that are often placed on our products in the areas of application concerned. We nevertheless expressly point out **that such statements cannot be regarded as binding statements about the suitability of our products for a particular customer application**. As a rule we are either unfamiliar with individual customer applications or less familiar with them than the customers themselves. For these reasons, it is always ultimately incumbent on the customer to check and decide whether a product with the properties described in the product specification is suitable for use in a particular customer application.
2. We also point out that **in individual cases, a malfunction of electronic components or failure before the end of their usual service life cannot be completely ruled out in the current state of the art, even if they are operated as specified**. In customer applications requiring a very high level of operational safety and especially in customer applications in which the malfunction or failure of an electronic component could endanger human life or health (e.g. in accident prevention or life-saving systems), it must therefore be ensured by means of suitable design of the customer application or other action taken by the customer (e.g. installation of protective circuitry or redundancy) that no injury or damage is sustained by third parties in the event of malfunction or failure of an electronic component.
3. **The warnings, cautions and product-specific notes must be observed.**
4. In order to satisfy certain technical requirements, **some of the products described in this publication may contain substances subject to restrictions in certain jurisdictions (e.g. because they are classed as hazardous)**. Useful information on this will be found in our Material Data Sheets on the Internet (www.tdk-electronics.tdk.com/material). Should you have any more detailed questions, please contact our sales offices.
5. We constantly strive to improve our products. Consequently, **the products described in this publication may change from time to time**. The same is true of the corresponding product specifications. Please check therefore to what extent product descriptions and specifications contained in this publication are still applicable before or when you place an order.

We also **reserve the right to discontinue production and delivery of products**. Consequently, we cannot guarantee that all products named in this publication will always be available. The aforementioned does not apply in the case of individual agreements deviating from the foregoing for customer-specific products.

6. Unless otherwise agreed in individual contracts, **all orders are subject to our General Terms and Conditions of Supply**.
7. **Our manufacturing sites serving the automotive business apply the IATF 16949 standard**. The IATF certifications confirm our compliance with requirements regarding the quality management system in the automotive industry. Referring to customer requirements and customer specific requirements ("CSR") TDK always has and will continue to have the policy of respecting individual agreements. Even if IATF 16949 may appear to support the acceptance of unilateral requirements, we hereby like to emphasize that **only requirements mutually agreed upon can and will be implemented in our Quality Management System**. For clarification purposes we like to point out that obligations from IATF 16949 shall only become legally binding if individually agreed upon.

Important notes

8. The trade names EPCOS, CarXield, CeraCharge, CeraDiode, CeraLink, CeraPad, CeraPlas, CSMP, CTVS, DeltaCap, DigiSiMic, FilterCap, FormFit, InsuGate, LeaXield, MediPlas, MiniBlue, MiniCell, MKD, MKK, ModCap, MotorCap, PCC, PhaseCap, PhaseCube, PhaseMod, PhiCap, PiezoBrush, PlasmaBrush, PowerHap, PQSine, PQvar, SIFERRIT, SIFI, SIKOREL, SilverCap, SIMDAD, SiMic, SIMID, SineFormer, SIOV, ThermoFuse, WindCap, XieldCap are **trademarks registered or pending** in Europe and in other countries. Further information will be found on the Internet at www.tdk-electronics.tdk.com/trademarks.

Release 2023-08